



4th Digital Transformation in Government Conference

CBSA Architecture Program: a Digitalization Enabler

15 June 2023

Bruno Ouellet, Director EA

PROTECTION SERVICE INTEGRITY
TY PROTECTION SERVICE INT
ÉGRITÉ PROTECTION SERVICE
INTEGRITY PROTECTION SERVI
CE INTÉGRITÉ PROTECTION SE
RVICE INTÉGRITÉ PROTECTION
SERVICE INTÉGRITÉ PROTECTI
ON SERVICE INTÉGRITÉ PROT
ECTION SERVICE INTÉGRITÉ PR
OTECTION SERVICE INTÉGRITY
PROTECTION SERVICE INTÉGRITÉ
TÉ PROTECTION SERVICE INT
TEGRITY PROTECTION SERVICE
INTÉGRITÉ PROTECTION SERVI
CE INTEGRITY PROTECTION SE





Table of Contents

Introduction

1

Context

2

Design
WITHOUT EA

3

Design WITH EA

4

Role of EA

Description

5

CBSA Architecture
Program

6

Review of 6 functions

7

Overview of the Agency
Collaboration Platform
(ACP)

Conclusion

8

Next Steps
for the CAP

9

Key Takeaways and
Questions

Context



Canadians expect modern and digital services from their government



CBSA has a very complex business landscape to manage which hardly copes with growing volumes/threats



CBSA's core business relates to risk management



Because of its complexity and needs, CBSA's future ecosystem **MUST** be architected!



WITHOUT Enterprise Architecture

Every time a new capability is being designed, its implementation lacks horizontal integration which leads to siloed design resulting in partial business value

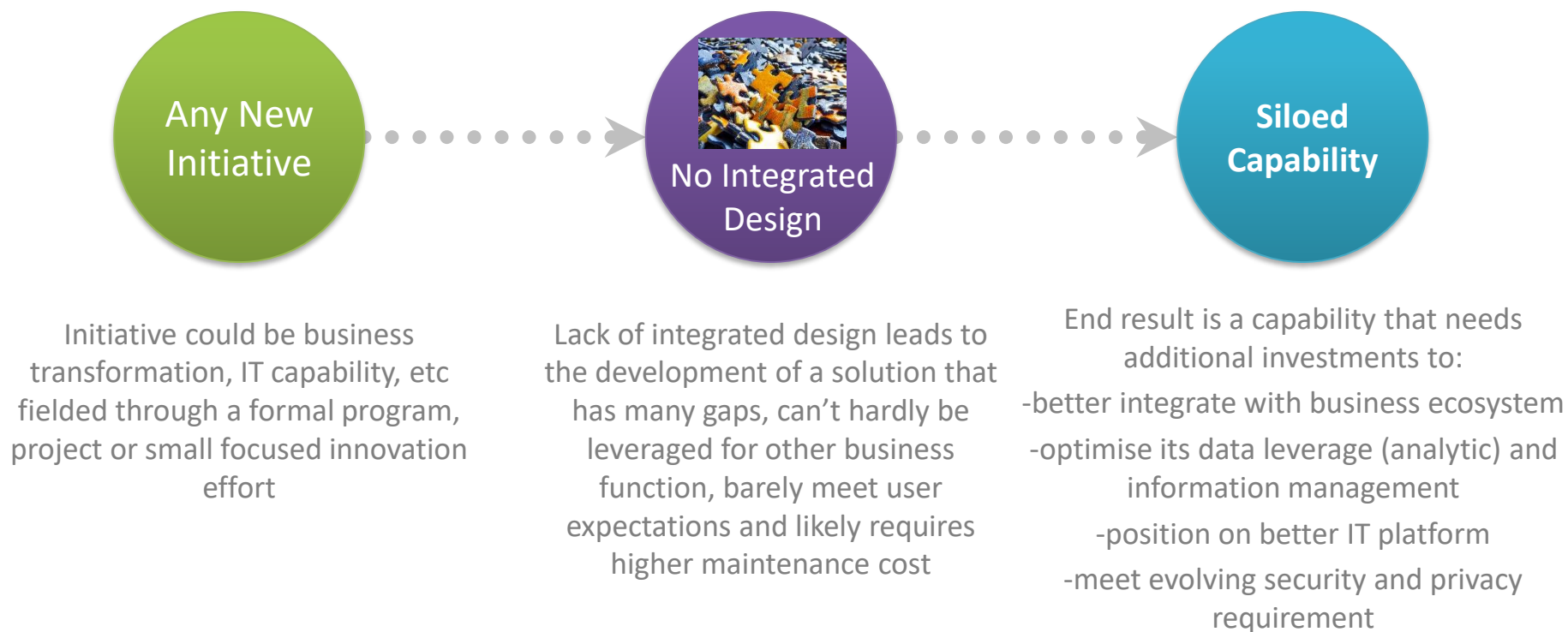

WITH Enterprise Architecture

Every time a new capability is being introduced, a by-design architecture function is applied to optimise its implementation into the current CBSA ecosystem which will ultimately bring a greater business value

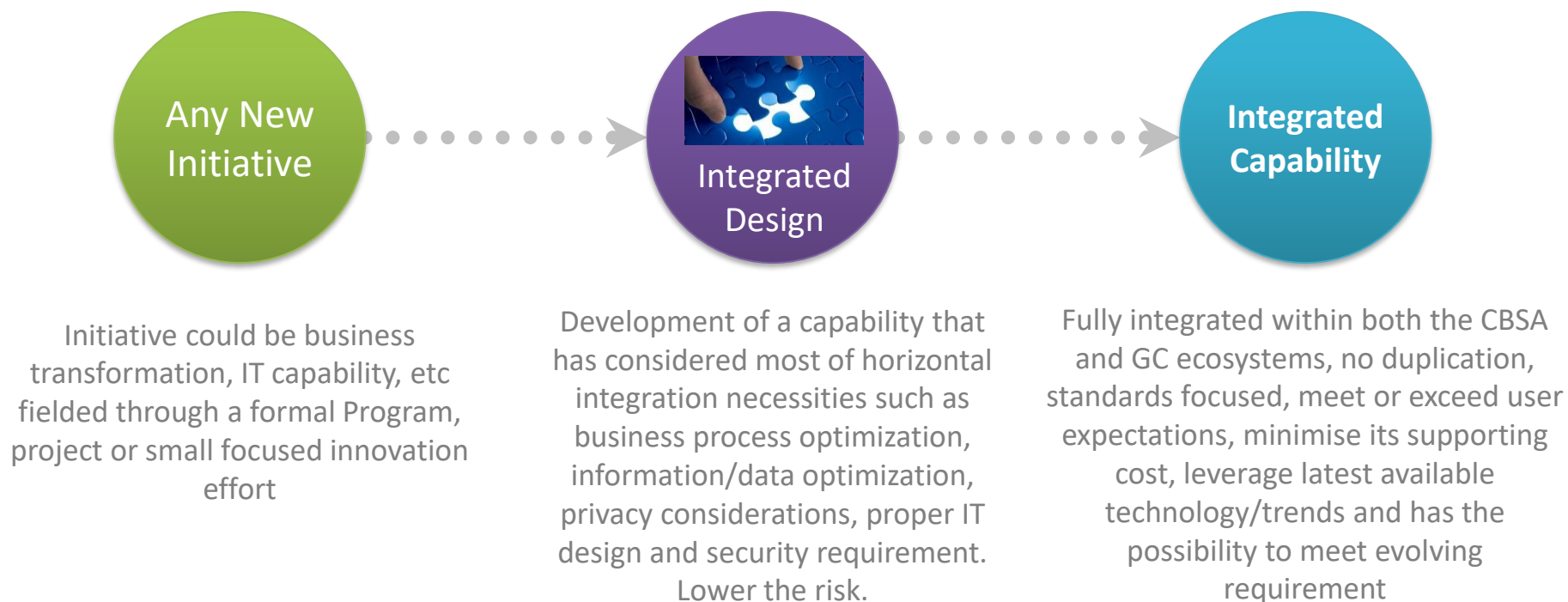



What EA wants to address:



01. Stovepipe design

No integration in ecosystem. No ability to easily exploit the information and data. Difficulty to maintain in the long run or to apply change.

02. Duplication

In business processes, in information objects, in application functions, in technology services, in security features, etc
No standardization

03. Technology debt

Resulting solution needs dedicated resources to maintain all functionalities. Additional cost needed to properly integrate into CBSA ecosystem. Restricted ability to innovate.

04. Poor user experience

Stovepipe design degrades user experience (business process not optimized, individual login required, identity management duplicated, etc)



What EA wants to promote:



01. Greater efficiency

Optimization within current business processes (LEAN). Better user experience. Tell us once applies. Ability to leverage analytic services to assist decision making.

02. Optimal integration

In business process, in info/data models and from an application functions perspective. No duplication and optimal use of enterprise capabilities (process inventory, MDM/RDM, SOA/API management, security services, etc

03. Digitalization

Optimal digitalization leads to optimal business process design. Better business and client outcome. Ability to further innovate.

04. Innovation

Modern and modularized design easier to support future innovation needs or opportunities.

CBSA Architecture Program (CAP)



What is the CAP all about?

- Integration of Business, Info/Data/Privacy, Application, Technology, Security domains
- Implementing changes in complex environment in an optimally integrated manner to bring greater value
- Increase accountability and understanding of design changes
- Increase adoption of Enterprise level capabilities
- Promote innovation and digitalization

What the CAP does?



Tracks and advocates for new trends and innovation applicable to CBSA



Promote architecture governance (functional authorities, CBSA ARB and GC EARB)



Develop and govern enterprise architecture direction jointly with stakeholders



Develop and maintain a CBSA Reference Architecture (Org Digital Twin) repository



By design support to business optimization, experimentation and transformation initiatives

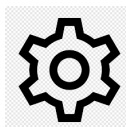

Steward of Business Process Management and Application Portfolio Management



Tracks and advocates for new trends and innovation



- Attend symposiums, conferences and discuss with industries
- Actively participate into Treasury Board, OGDs and internal working groups
- Integrated into the CBSA innovation teams
- Leverage professional services such as Gartner, McKinsey, Info-Tech, etc
- Train ourselves into promising technology (AI, block chain, etc)
- Write short white papers on new technology trends



Develop and Govern Enterprise Architecture Direction



- Develop jointly with key stakeholders :
 - White papers
 - Vision
 - Reference Architecture (e.g. ICAM, Digital Service Platform, Case Management)
 - Framework (e.g. AI, mobile platform, RPA, Info/data management, etc)
 - Description
 - Standard declarations
- Communicate and share them (EA CoP)
- Govern with functional authorities and at Director, DG and CBSA ARB level



By Design Support to CBSA Optimization, Experimentation and Transformation Initiatives

- The CAP is integrated in:
 - Investment Planning and Project Management Life Cycles
 - Benefit Realization Management Framework
 - Service Management Life Cycle Framework and Agile Framework (IT service delivery)
 - Innovation Framework
- For each initiative above \$1M (digital or not):
 - We assess architecture alignment from gate to gate and also for all IT releases
 - We document business processes, identify information objects/flows and corresponding application services
 - We provide implementation impact assessment





Promote Architecture Governance



- Support architecture governance for all initiatives above \$1M
- Engage and brief functional authorities as need be (CIO, CSO, CDO, Cyber Authority Official, Service Authority Official, etc)
- Engage operational leads (CTB, TB, IEB)
- Act as CBSA ARB Secretariat
 - Set up agenda, produce RoDs
 - Review presentation material
- Coordinate all TBS and GC EARB architecture artefact reviews and/or presentations
- Report CAP Key Performance Indicators (KPI) to CBSA ARB

Steward of Business Process Management and Application Portfolio Management

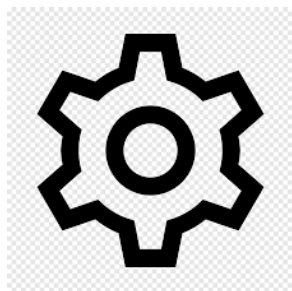

- BPM
 - BPM CoE
 - Steward of the BPM practice at CBSA
 - Assist operational authority to document, validate and Lean their respective continuum
 - Assist internal services (IT, HR, finance, etc) in their efficiency quest
- Application Portfolio Management
 - Steward of CBSA APM practice
 - Coordinate jointly with stakeholders the production of the yearly TBS report
 - APM includes:
 - National and Local/Regional applications
 - Business assessment of each application
 - Financial assessment of each application



Develop and Maintain a CBSA Reference Architecture Repository



- Agency Collaboration Platform (ACP)
 - Qualiware product
 - Integrates all architecture domains:
 - Business, Information/Data/Privacy, Application, Technology and Security
- Internal web-based, accessible to all
- Used as golden record
- Information maintained directly in the repository via governance engine
- Views and reporting tailored to user needs
- Supported via CBT
- Contains architecture assessments, tracked initiatives, variances, current EA delivery plan, meta models, Digital Product Directory, etc



Repository is based on this Conceptual CBSA Reference Architecture (blueprint) Model

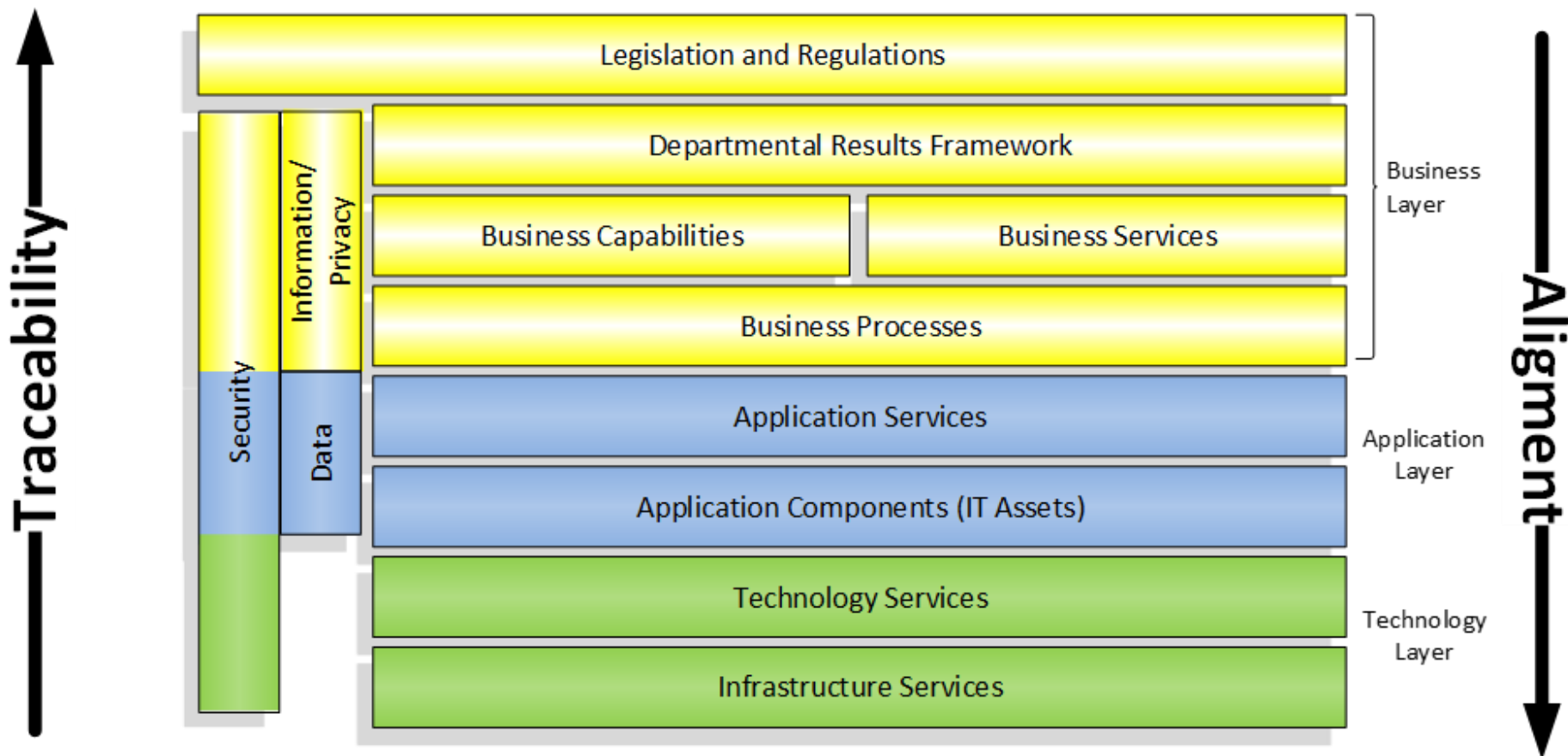

Annex A details the overall content



Architecture Collaboration Platform – Quick Overview

The screenshot displays the Architecture Collaboration Platform (ACP-PCA) interface. The browser address bar shows the URL <https://acp-pca.omega.dce-eir.net/Production/>. The page features a navigation menu with the following items: HOME | ACCUEIL, BUSINESS | AFFAIRES, APPLICATION | APPLICATION, ARCHITECTURE PROGRAM | PROGRAMME D'ARCHITECTURE, INITIATIVE/PROJECT | INITIATIVE/PROJET, and HELP | AIDE. A vertical sidebar on the left contains categories: STRATEGY | STRATÉGIE, BUSINESS | AFFAIRES, INFORMATION & DATA | INFO. & DONNÉES, APPLICATION | APPLICATION, TECHNOLOGY | TECHNOLOGIE, SECURITY & PRIVACY | SÉCURITÉ & CONFID., ARCHITECTURE OPS. | OPS. D'ARCHITECTURE, and ACP TRAINING | FORMATION PCA. The main content area is divided into several panels: 'Quick Search' with input fields for Program, Business Service, Business Process, Business Object, and Business Capability; 'CBSA Organization' showing a hierarchical organizational chart; 'CBSA Programs' with a flow diagram; 'CBSA Business Services' with a grid of service icons; 'CBSA Business Processes' with a Gantt-style process chart; 'CBSA Business Capabilities' with a table of capabilities; and 'Understanding the Architecture' with a complex architectural diagram. The 'qualiwareX' logo is visible in the bottom left corner of the interface.



CBSA Program Inventory (18)

K ACP - PCA

STRATEGY | STRATÉGIE
BUSINESS | AFFAIRES
INFORMATION & DATA | INFO. & DONNÉES
APPLICATION | APPLICATION
TECHNOLOGY | TECHNOLOGIE
SECURITY & PRIVACY | SÉCURITÉ & CONFID.
ARCHITECTURE OPS. | OPS. D'ARCHITECTURE
ACP TRAINING | FORMATION PCA

CB SA Program Inventory [LayeredArchitectureView:CB SA]

DIAGRAM DESCRIPTION SYMBOL CATALOGUE CONNECTOR CATALOGUE COMMENTS CHANGE REQUESTS WORKFLOW HISTORY RASCI CONTEXT VIEW

Create Change Request Subscribe

Layered Architecture View : CBSA

Name: CBSA Program Inventory

System-of-Interest: [Canada Border Services Agency](#)

Primary AD: [CBSA-RA](#)

Sub Scope:

Revision: 1 Last Modified Date: 2022-04-06

Status: Approved Status Date: 2022 04 06 15:14:07

Sensitivity:

Border Management	Border Enforcement	Internal Services
Program <ul style="list-style-type: none">Anti-Dumping and CountervailingBuildings and EquipmentCommercial Facilitation and ComplianceField Technology SupportForce GenerationIntelligence Collection and AnalysisSecurity ScreeningRecourseTargetingTrade Facilitation and ComplianceTraveller Facilitation and ComplianceTrusted TraderTrusted Traveller	Program <ul style="list-style-type: none">Immigration InvestigationsDetentionsHearingsCriminal InvestigationsRemovals	Internal Service <ul style="list-style-type: none">Acquisition Management ServicesCommunications ServicesFinancial Management ServicesHuman Resources Management ServicesInformation Management ServicesInformation Technology ServicesLegal ServicesManagement and Oversight ServicesMaterial Management ServicesReal Property Management Services

qualiware



Commercial Facilitation & Compliance Program Canvas

Program Canvas Model

Name: Commercial F&C-RA-Program Canvas

System-of-Interest: Segment Commercial Facilitation and Compliance

Primary AD: Commercial Facilitation and Compliance-RA

Sub Scope:

Revision: 3 Last Modified Date: 2022-12-12

Status: Approved Status Date: 2022 12 12 12:25:35

Sensitivity:

The Commercial Facilitation and Compliance program administers legislation, regulations and international free trade agreements, as well as develops and administers the regulations, policies, procedures, partnerships and national programs that facilitate the import and export of legitimate goods within established service standards, into and out of Canada. This includes the design, development and maintenance of commercial policy for goods being imported into Canada as well as developing tools, training materials and guidance to support the regional delivery of these core programs. To minimize intervention, the program works with its external partners to promote voluntary compliance; to use risk assessment information at the border; and to conduct post-border compliance verifications. It also supports the development of transformation / modernization priority initiatives such as the eManifest, Commercial Policy Review, eCommerce Strategy as well as other modernization initiatives.

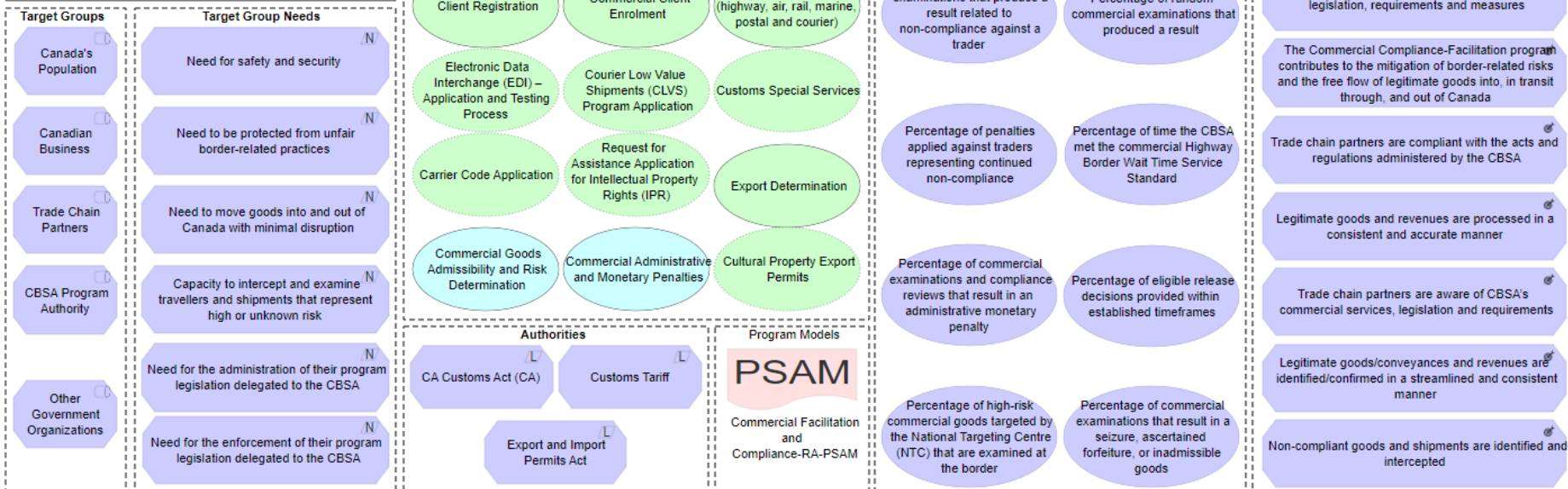

PSAM - Detentions (sample)

Program Service Alignment Model	
Name: Commercial Facilitation and Compliance-RA-PSAM	Diagram Legend
System-of-Interest: Segment:Commercial Facilitation and Compliance	
Primary AD: Commercial Facilitation and Compliance-RA	
Sub Scope:	
Revision: 0	Last Modified Date:2022-04-06
Status: Approved	Status Date: 2022 04 06 15.18:45
Sensitivity:	

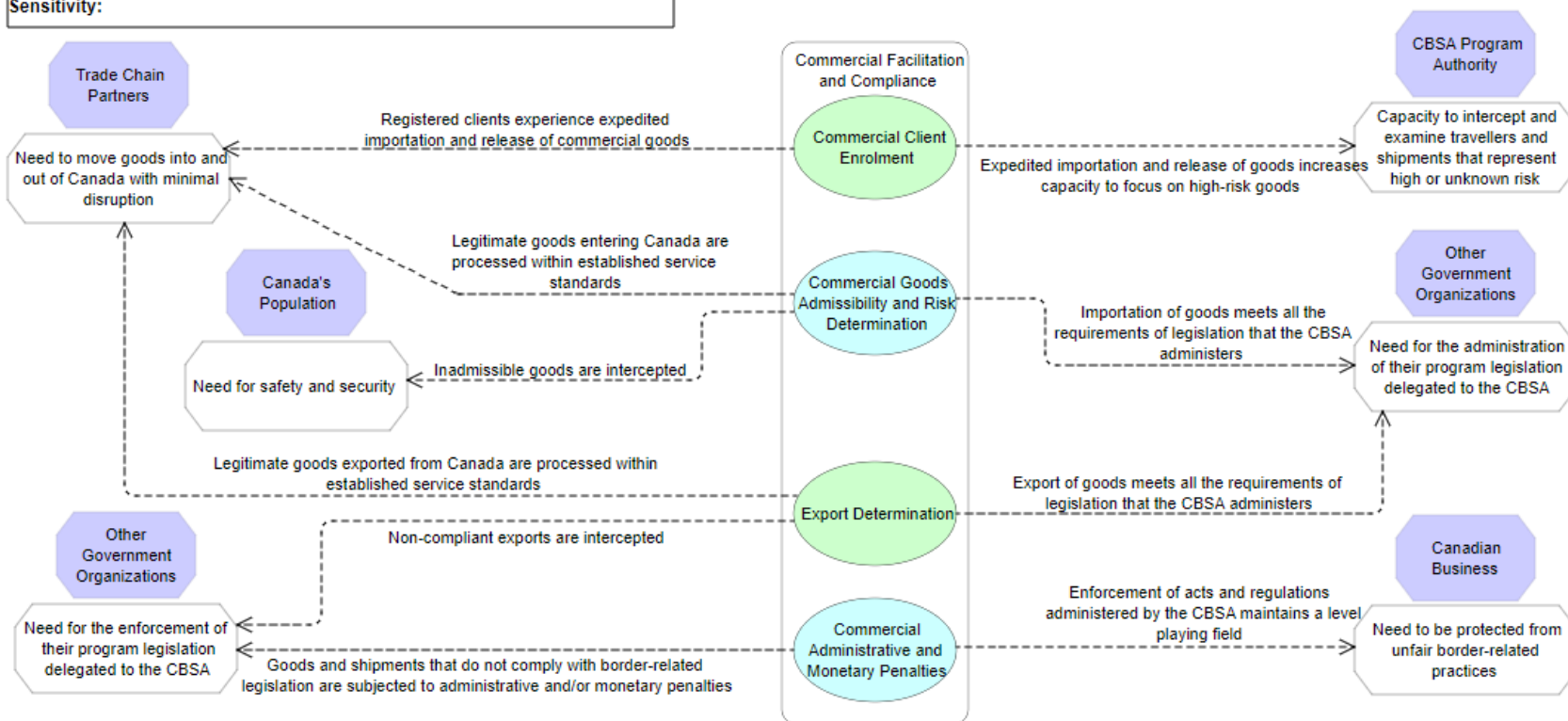



CBSA Service Inventory (141)

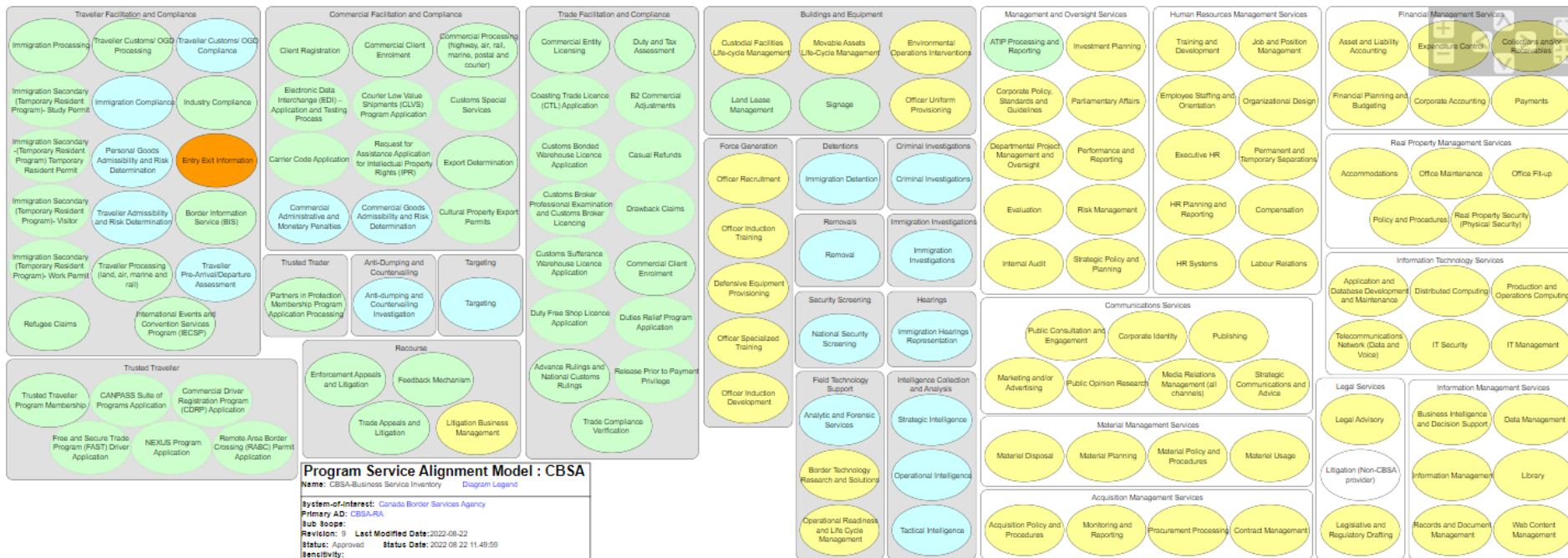

Green: External service

Yellow: Internal service

Blue: Societal service

Orange: Service provided to an external entity

White: Non CBSA service



Traveller Facilitation and Compliance Service Canvas

Business Service Canvas Model : Traveller Facilitation and Compliance
 Name: Trav F&C-RA-BSC: Traveller Processing
 System-of-Interest: Segment: Traveller Facilitation and Compliance
 Primary AD: Traveller Facilitation and Compliance-RA
 Sub Scope:
 Revision: 6 Last Modified Date: 2022-11-24
 Status: Approved Status Date: 2022 11 24 13:08:44
 Sensitivity:

Traveller Processing (land, air, marine and rail)
 Service Description
 The CBSA receives and processes travellers entering at Canadian POEs via air, highway, marine and rail mode.
 Service Scope: External
 Include in Inventory: Yes
 High Volume Regulatory Transaction: No
 Service Output: A processed Traveller
 Service Output Type: Findings
 Service Type: Agreements, Permissions, Inspections, Rulings
 Last Year of Service Review: 2017-2018 Essential: Yes Critical: Yes

Business Service Models
SIAM
 Trav F&C-RA-SIAM: POE Traveller Processing
 Service Value Proposition
None Identified

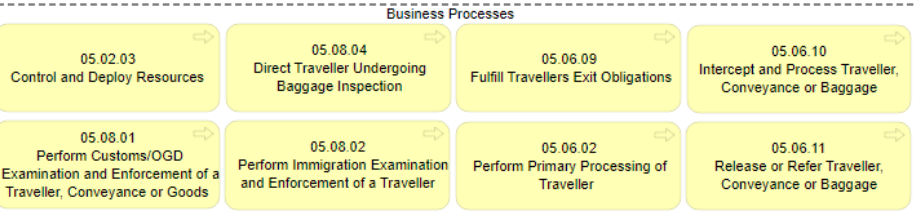
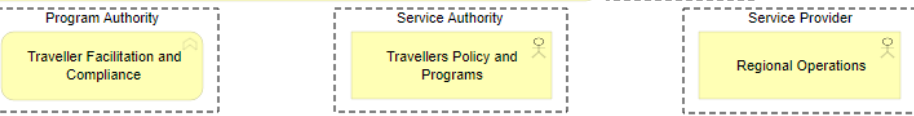
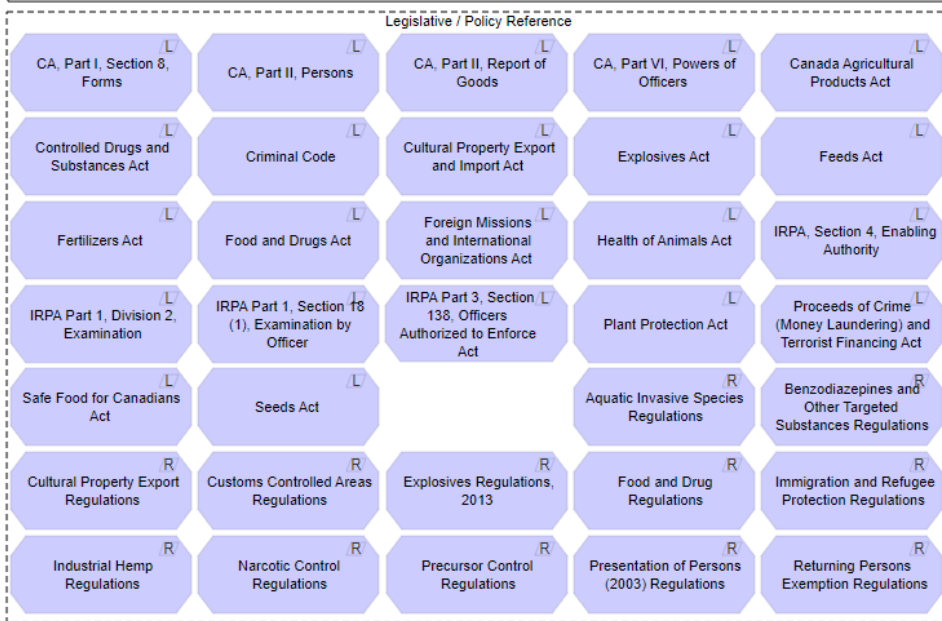



SIAM - Detentions

Service Integration Accountability Model
Name: Detentions-RA-SIAM
System-of-Interest: [Segment:Detentions](#)
Primary AD: [Detentions-RA](#)
Sub Scope: [Immigration Detention](#)
Revision: 3 Last Modified Date:2022-03-10
Status: Approved Status Date: 2022 03 10 19:18:22
Sensitivity:

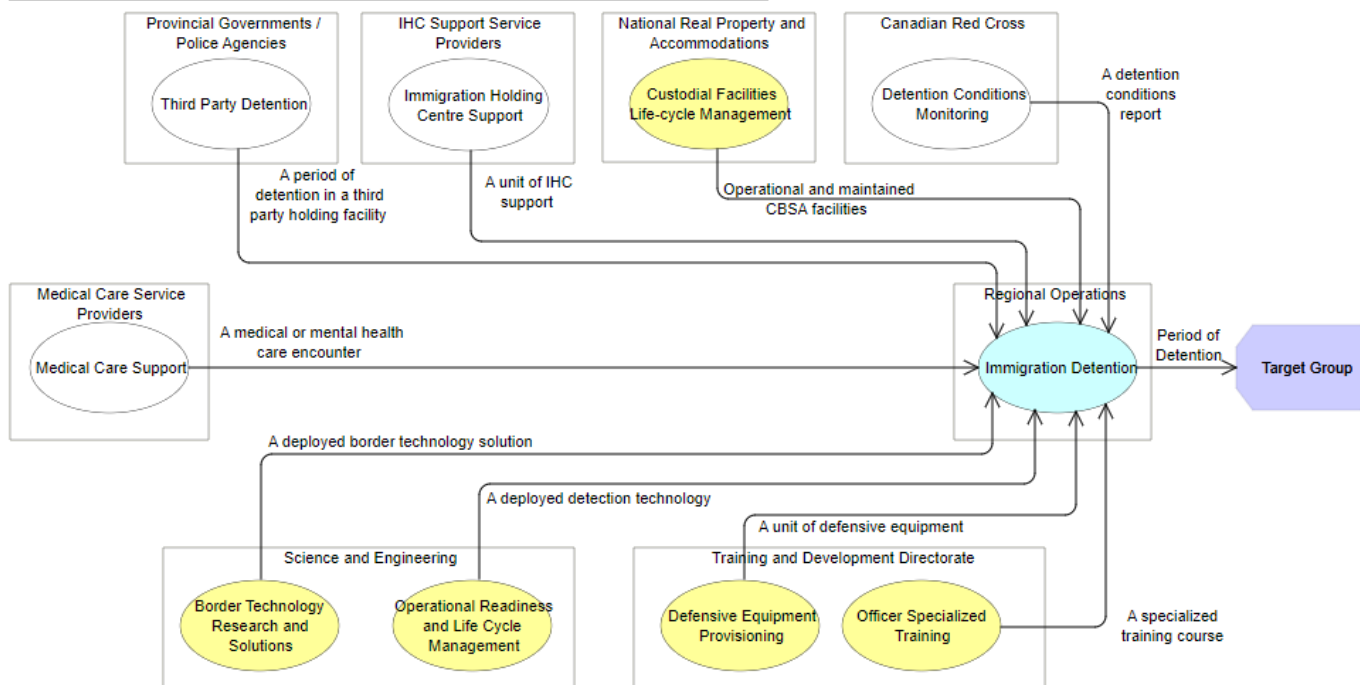



Process Inventory (over 500)

- BUSINESS | AFFAIRES
- INFORMATION & DATA | INFO. & DONNÉES
- APPLICATION | APPLICATION
- TECHNOLOGY | TECHNOLOGIE
- SECURITY & PRIVACY | SÉCURITÉ & CONFID.
- ARCHITECTURE OPS. | OPS. D'ARCHITECTURE
- ACP TRAINING | FORMATION PCA

DIAGRAM	DESCRIPTION	SYMBOL CATALOGUE	CONNECTOR CATALOGUE	COMMENTS	CHANGE REQUESTS	WORKFLOW HISTORY	RASCI	CONTEXT VIEW
---------	-------------	------------------	---------------------	----------	-----------------	------------------	-------	--------------

01	02	03	04	05	06	07	08	09	10	11	12	13
01.01	02.01	03.01	04.01	05.01	06.01	07.01	08.01	09.01	10.01	11.01	12.01	13.01
01.02	02.02	03.02	04.02	05.02	06.02	07.02	08.02	09.02	10.02	11.02	12.02	13.02
01.03	02.03	03.03	04.03	05.03	06.03	07.03	08.03	09.03	10.03	11.03	12.03	13.03
02.04	03.04	04.04	05.04	06.04	07.04	08.04	09.04	10.04	11.04	12.04	13.04	
	03.05	04.05	05.05	06.05	07.05	08.05	09.05	10.05	11.05	12.05	13.05	
	03.06		05.06	06.06	07.06	08.06	09.06	10.06	11.06	12.06	13.06	
			05.07	06.07	07.07	08.07	09.07	10.07	11.07	12.07	13.07	
			05.08	06.08	07.08	08.08	09.08	10.08	11.08	12.08	13.08	
			05.09								13.09	

Process Category Framework Model : CBSA
 Name: CBSA-RA-PCF-Level 1
 System-of-Interest: Canada Border Services Agency
 Primary AD: CBSA-RA
 Sub Scope:
 Revision: 6 Last Modified Date: 2023-03-07
 Status: Approved Status Date: 2023-03-07 21:17:47
 Sensitivity: Unclassified



Perform Commercial Import/Export Risk Assessment Process Canvas

Business Process Canvas Model
 Name: 05.05.03 Perform Commercial Import/Export Risk Assessment
 System-of-Interest:
 Primary AD:
 Sub Scope:
 Revision: 17 Last Modified Date:2023-05-05
 Status: Approved Status Date: 2023 05 03 19.26.02
 Sensitivity:

Name: Perform Commercial Import/Export Risk Assessment
 PCF Reference: 05.05.03
 Type: Functional
 Short Description: Perform risk assessment of a commercial import or export shipment by analyzing information either sent to the CBSA or already contained in a CBSA, PGA, partner or open source data store.
 Pre-Conditions:
 Post-Conditions:

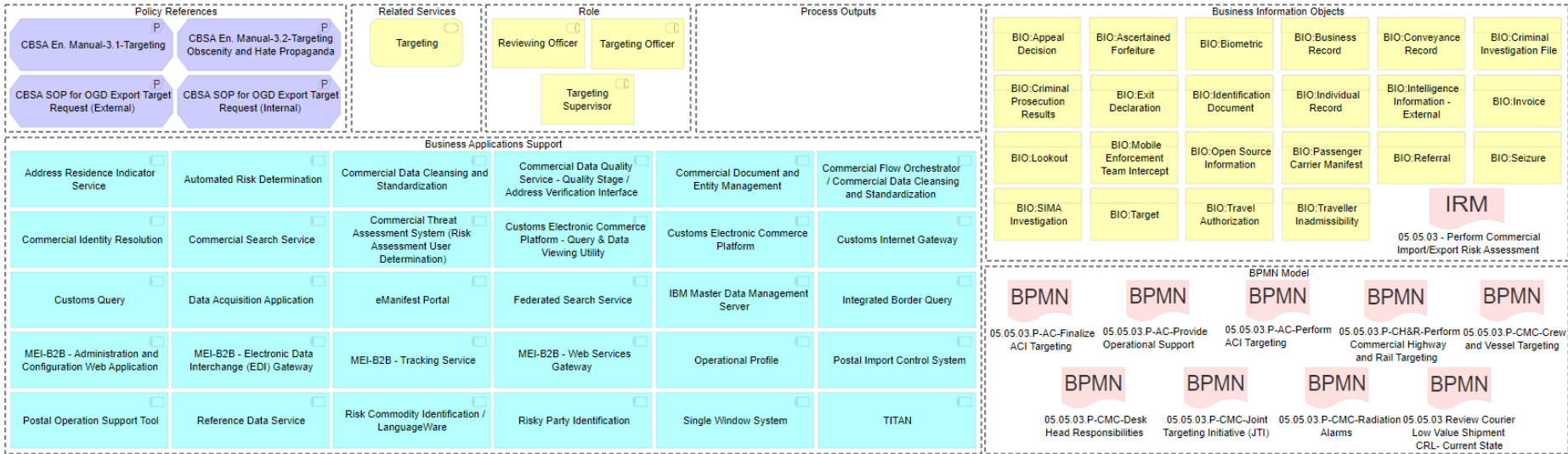



IRM – Perform Commercial Import/Export Risk Assessment

Information Requirement Model
Name: 05.05.03 - Perform Commercial Import/Export Risk Assessment
System-of-Interest:
Primary AD:
Sub Scope:
Revision: 6 Last Modified Date:2023-05-05
Status: Approved Status Date: 2022 12 14 16.50:56
Sensitivity:

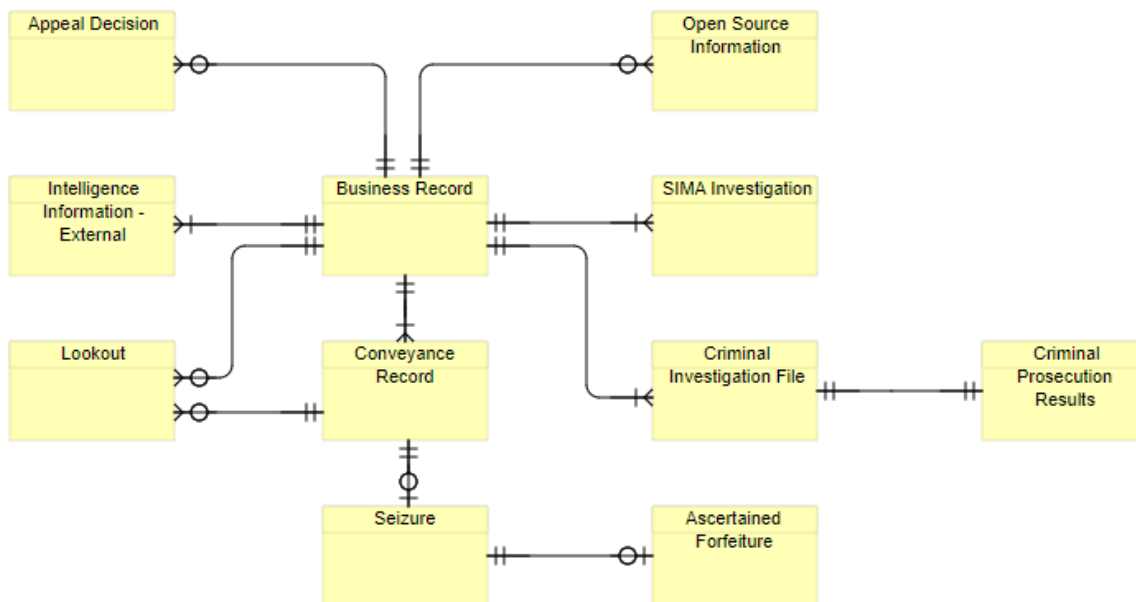



BPMN Process Diagram

Business Process Diagram
Name: 05.05.03 Review Courier Low Value Shipment CRL - Current State [Diagram Legend](#)
System-of-Interest:
Primary AD:
Sub Scope:
Revision: 0 Last Modified Date: 2022.06.10
Status: Approved Status Date: 2022.06.10 13.22:40
Sensitivity:

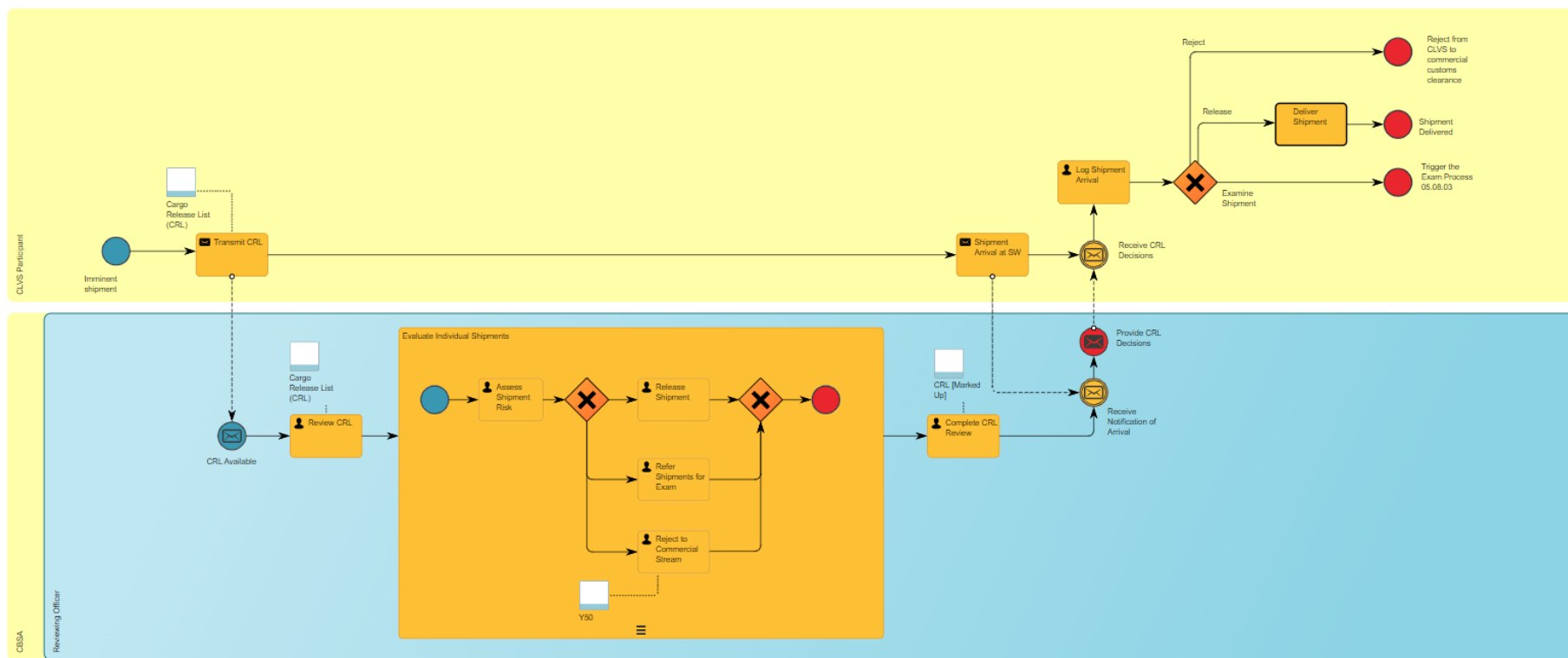



Next Steps for the CAP

- Advise CBSA investment decisions
- Bring more stakeholders into the ACP development + information maintenance
- Set the ACP to host solution architecture
- Continue to perform BPM and launch LEAN role services
- Update our overall architecture method

Key Takeaways

- The CBSA Architecture Program:
 - Supports all business transformational (incl **digitalization**) activities across CBSA, not just IT
 - Game changer moments:
 - Integration in SLMF in 2015
 - Integration in PMF and CBSA ARB stand up in 2020
 - **Business architecture is the leading architecture domain!**
- The CAP is a huge enabler of the integration requirement stated in the new Policy/Directive on Services and Digital





Annex A - Complexity of the CBSA

- 18 Programs and 10 Internal Service groupings
- 300+ CBSA, Other Agency and Private Sector Organizational references
- 138 Business Services
- 1200+ Business Processes, sub-processes and process activities
- 96 Acts of Parliament and over 450+ specific Legislative References
- 228 Regulations
- 968 Policy References
- 179 Business Information Objects and 72 Info Requirement models
- 123 Agency and Program Outcomes
- 253 KPIs
- 310+ Business Roles
- 185 National Apps, 98 local and 105 regional Apps